

E/SV Series Tantalum Chip Capacitors

■ FEATURES

- Lead-free Type.
- Offer a range of small, high-capacity models.
- Succeed to the latest technology plus outstanding performance.

■ DIMENSIONS [mm]

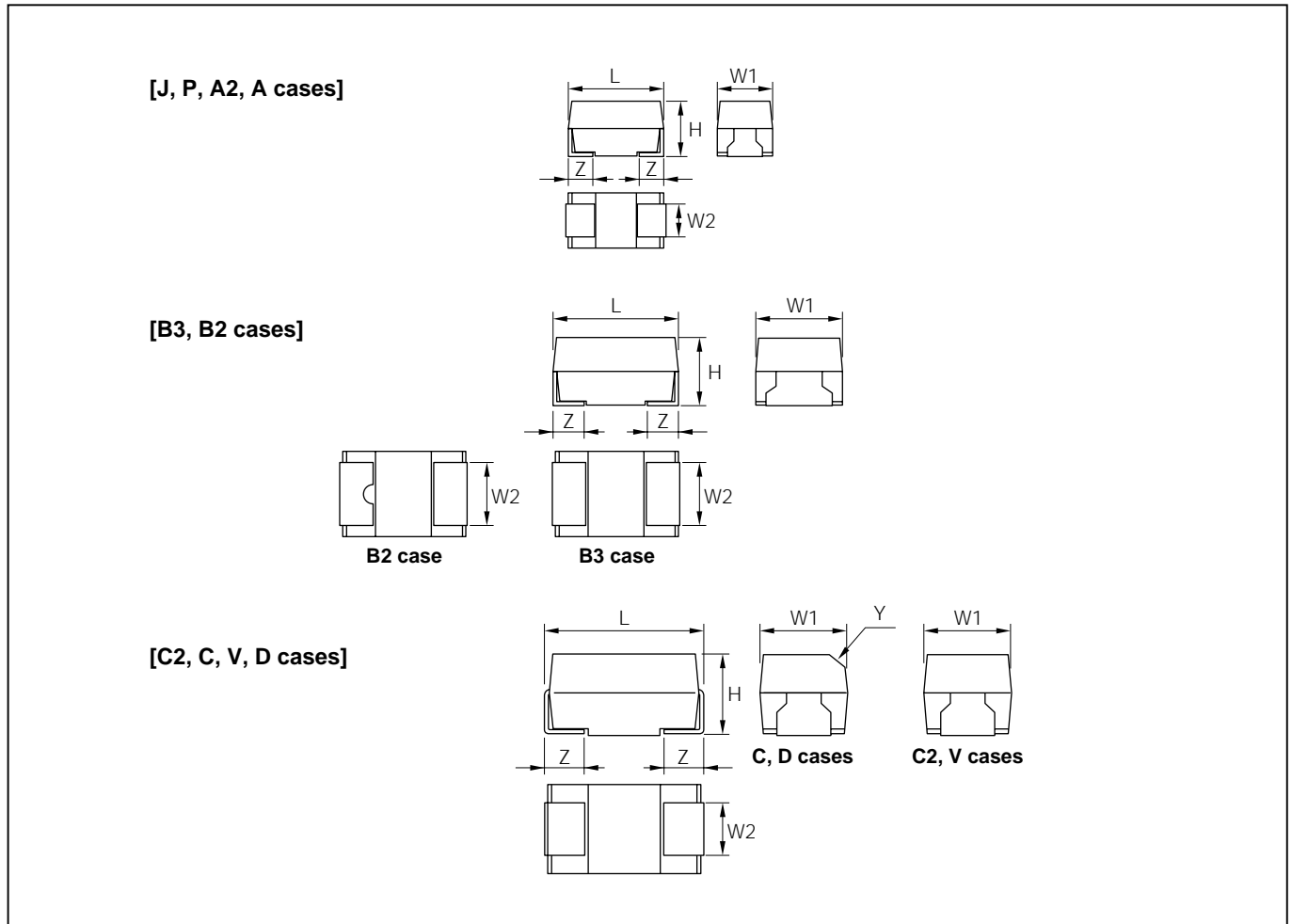

(Unit: mm)

Case Code	EIA code	L	W ₁	W ₂	H	Z	Y
J	—	1.6 ± 0.1	0.8 ± 0.1	0.6 ± 0.1	0.8 ± 0.1	0.3 ± 0.15	—
P	2012	2.0 ± 0.2	1.25 ± 0.2	0.9 ± 0.1	1.1 ± 0.1	0.5 ± 0.1	—
A2 (U)	3216L	3.2 ± 0.2	1.6 ± 0.2	1.2 ± 0.1	1.1 ± 0.1	0.8 ± 0.2	—
A	3216	3.2 ± 0.2	1.6 ± 0.2	1.2 ± 0.1	1.6 ± 0.2	0.8 ± 0.2	—
B3 (W)	3528L	3.5 ± 0.2	2.8 ± 0.2	2.2 ± 0.1	1.1 ± 0.1	0.8 ± 0.2	—
B2 (S)	3528	3.5 ± 0.2	2.8 ± 0.2	2.2 ± 0.1	1.9 ± 0.2	0.8 ± 0.2	—
C2	—	6.0 ± 0.2	3.2 ± 0.2	2.2 ± 0.1	1.4 ± 0.1	1.3 ± 0.2	—
C	6032	6.0 ± 0.2	3.2 ± 0.2	2.2 ± 0.1	2.5 ± 0.2	1.3 ± 0.2	0.4 C
V	—	7.3 ± 0.2	4.3 ± 0.2	2.4 ± 0.1	1.9 ± 0.1	1.3 ± 0.2	—
D	7343	7.3 ± 0.2	4.3 ± 0.2	2.4 ± 0.1	2.8 ± 0.2	1.3 ± 0.2	0.5 C

■ STANDARD C-V VALUE REFERENCE BY CASE CODE

μF \ U _R	2.5 V	4 V	6.3 V	10 V	16 V	20 V	25 V	35 V
0.47					P	A2	A	A
0.68					P	A2	A	A
1.0				P	J, P	A2	A2, A	A2, A
1.5			P	J, P	A	A2		A
2.2			J	J, P	A2, A	A2, A	A	B2
3.3		P	J	P, A2	A2, A	A, B3	A	B2
4.7			J, P, A	P, A2, A	A2, A	A, B3, B2	B2	C
6.8		J	J, P, A2	A	A, B3	B2		C
10	J	J, P	J, P, A2, A	A2, A, B2	A, B3, B2	B2	C	D
15		P	A2, A	B3	B2	C		D
22	P, A2	P, A2, A	A2, A, B3, B2	A, B3, B2	B2, C	C2, C, D	D	
33	P	A2, A	A, B3	B2	C2, C	D		
47	P, A2, A	A, B3	A, B3, B2, C	B2, C2, C	C, D	D		
68	A	B3	B2	C	D			
100	B3, B2	A, B3, B2	B2, C2, C	C, D	D			
150	B2	B2	C	D				
220	B2	B2, C	C, D, V	D				
330	C	C, V	D					
470	C, D	D	D					
680		D						

■ PART NUMBER SYSTEM

[Bulk]

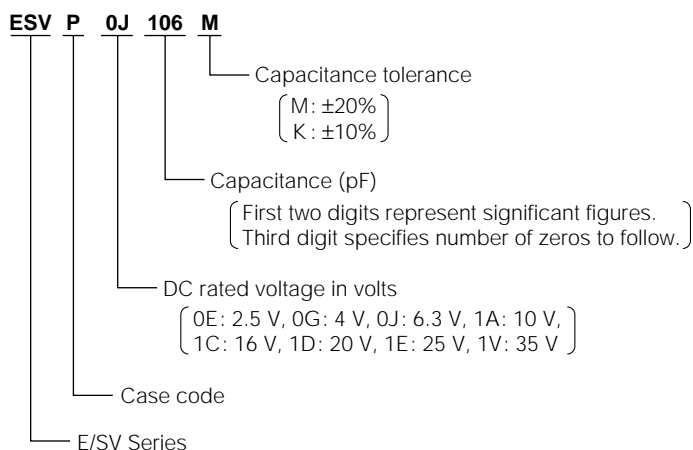

[Tape and Reel]

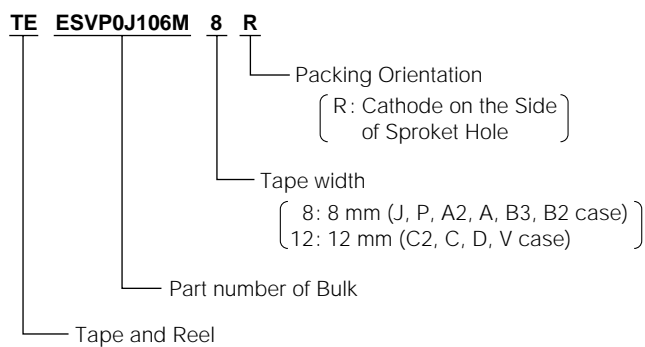

MARKINGS

The standard marking shows capacitance, DC rated voltage, and polarity.

[J case] (ex. 4.7 μ F / 6.3 V)

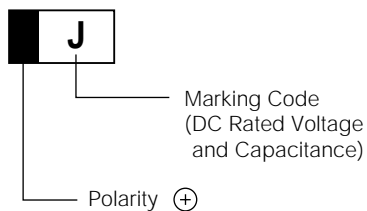

[J case Marking Code]

μ F \ U _R	2.5 V	4 V	6.3 V	10 V	16 V
1.0					⊘
1.5				V	
2.2			Γ	A	
3.3			↵		
4.7			J		
6.8		G	⌒		
10	e	⊘	Γ̄		

[P case] (ex. 1 μ F / 10 V)

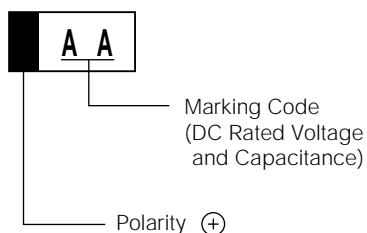

[P case Marking Code]

μ F \ U _R	2.5 V	4 V	6.3 V	10 V	16 V
0.47					CS
0.68					CW
1				AA	CA
1.5			JE	AE	
2.2				AJ	
3.3		GN		AN	
4.7			JS	AS	
6.8			JW		
10		GĀ	JĀ		
15		GĒ			
22	eĴ	GĴ			
33	eÑ				
47	eŠ				

[A2, A cases] (ex. 10 μ F / 6.3 V)

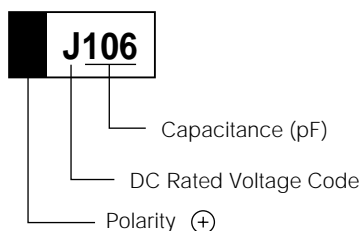

[P, A2, A, cases DC Rated Voltage code]

Code	e	G	J	A	C	D	E	V
Rated Voltage	2.5 V	4 V	6.3 V	10 V	16 V	20 V	25 V	35 V

[B3, B2 cases] (ex. 47 μ F / 6.3 V)

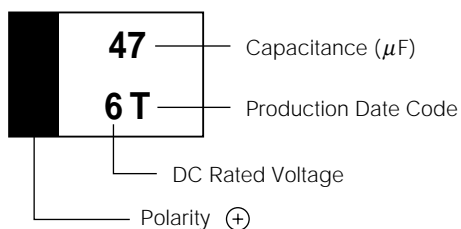

[B3, B2, C2, C, V, D cases Production date code]

y \ M	Jan.	Feb.	Mar.	Apr.	May	Jun.	Jul.	Aug.	Sep.	Oct.	Nov.	Dec.
2001	A	B	C	D	E	F	G	H	J	K	L	M
2002	N	P	Q	R	S	T	U	V	W	X	Y	Z
2003	a	b	c	d	e	f	g	h	j	k	l	m
2004	n	p	q	r	s	t	u	v	w	x	y	z

Note: Production date code will repeat beginning in 2005.

[C2, C, V, D cases] (ex. 220 μ F / 6.3 V)

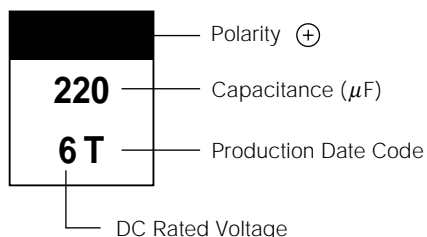

■ PERFORMANCE CHARACTERISTICS

ITEM	PERFORMANCE							
Operating Temperature	-55 to +125°C							
Rated Voltage	2.5 V	4 V	6.3 V	10 V	16 V	20 V	25 V	35 V
Working Voltage at 125°C	1.6 V	2.5 V	4 V	6.3 V	10 V	13 V	16 V	22 V
Surge Voltage at 85°C	3.3 V	5.2 V	8 V	13 V	20 V	26 V	33 V	46 V
Capacitance (at 20°C, 120 Hz)	Range : 0.47 μF to 680 μF Tolerance : ±20% (±10%)							
Capacitance Change with Temperature	Not to exceed -20% (P, J case) or -12% at -55°C, +20% (P, J case) or +12% at 85°C, +20% (P, J case) or +15% at 125°C							
DC Leakage Current	0.01C • V (μA) or 0.5 μA, Whichever is Greater							
Tangent of Loss Angle	Refer to Standard Ratings							
Damp Heat (90 to 95%RH at 40°C, 56 days (1344hrs.))	Capacitance Change : Refer to Standard Ratings Tangent of Loss Angle : 150% of Initial Requirements DC Leakage Current : Initial Requirements							
Endurance (at 85°C, DC Rated Voltage, 2000hrs.)	Capacitance Change : Refer to Standard Ratings Tangent of Loss Angle : Initial Requirements DC Leakage Current : 200% (P, J case) or 125% of Initial Requirements							
Resistance to Soldering Heat (solder reflow at 260°C, 10 s or solder dip at 260°C, 5 s)	Capacitance Change : Refer to Standard Ratings Tangent of Loss Angle : Initial Requirements DC Leakage Current : Initial Requirements							

STANDARD RATINGS

Rating (V)	Part Number	Capacitance (μF)	Case Code	DC Leakage Current (μA)	Tangent of Loss Angle			Capacitance Change	
					+20°C +85°C	-55°C	+125°C	at Damp Heat at Resistance to Soldering Heat	at Endurance
2.5	ESVJ0E106M	10	J	0.5	0.20	0.30	0.30	$\pm 20\%$	$\pm 20\%$
	ESVP0E226M	22	P	0.5	0.20	0.30	0.30	$\pm 20\%$	$\pm 20\%$
	ESVA20E226M	22	A2	0.5	0.12	0.20	0.14	$\pm 12\%$	$\pm 12\%$
	ESVP0E336M	33	P	0.8	0.20	0.30	0.30	$\pm 20\%$	$\pm 20\%$
	ESVP0E476M	47	P	1.1	0.30	0.60	0.40	$\pm 20\%$	$\pm 20\%$
	ESVA20E476M	47	A2	1.1	0.12	0.22	0.14	$\pm 12\%$	$\pm 12\%$
	ESVA0E476M	47	A	1.1	0.12	0.22	0.16	$\pm 12\%$	$\pm 12\%$
	ESVA0E686M	68	A	1.7	0.18	0.34	0.20	$\pm 12\%$	$\pm 12\%$
	ESVB30E107M	100	B3	2.5	0.18	0.34	0.20	$\pm 15\%$	$\pm 15\%$
	ESVB20E107M	100	B2	2.5	0.08	0.14	0.10	$\pm 12\%$	$\pm 12\%$
	ESVB20E157M	150	B2	3.7	0.16	0.30	0.18	$\pm 12\%$	$\pm 12\%$
	ESVB20E227M	220	B2	5.5	0.18	0.34	0.20	$\pm 12\%$	$\pm 12\%$
	ESVC0E337M	330	C	8.2	0.16	0.34	0.18	$\pm 12\%$	$\pm 12\%$
ESVC0E477M	470	C	11.7	0.18	0.34	0.20	$\pm 12\%$	$\pm 12\%$	
ESVD0E477M	470	D	11.7	0.14	0.18	0.16	$\pm 12\%$	$\pm 12\%$	
4	ESVPOG335M	3.3	P	0.5	0.20	0.30	0.30	$\pm 20\%$	$\pm 20\%$
	ESVJ0G685M	6.8	J	0.5	0.20	0.30	0.30	$\pm 20\%$	$\pm 20\%$
	ESVJ0G106M	10	J	0.5	0.20	0.30	0.30	$\pm 20\%$	$\pm 20\%$
	ESVPOG106M	10	P	0.5	0.20	0.30	0.30	$\pm 20\%$	$\pm 20\%$
	ESVPOG156M	15	P	0.6	0.20	0.30	0.30	$\pm 20\%$	$\pm 20\%$
	ESVPOG226M	22	P	0.8	0.20	0.30	0.30	$\pm 20\%$	$\pm 20\%$
	ESVA20G226M	22	A2	0.8	0.12	0.22	0.16	$\pm 12\%$	$\pm 12\%$
	ESVA0G226M	22	A	0.8	0.08	0.12	0.10	$\pm 12\%$	$\pm 12\%$
	ESVA20G336M	33	A2	1.3	0.08	0.14	0.10	$\pm 12\%$	$\pm 12\%$
	ESVA0G336M	33	A	1.3	0.10	0.14	0.12	$\pm 12\%$	$\pm 12\%$
	ESVA0G476M	47	A	1.8	0.12	0.22	0.14	$\pm 12\%$	$\pm 12\%$
	ESVB30G476M	47	B3	1.8	0.12	0.18	0.15	$\pm 15\%$	$\pm 15\%$
	ESVB30G686M	68	B3	2.7	0.15	0.28	0.17	$\pm 15\%$	$\pm 15\%$
	ESVA0G107M	100	A	4.0	0.30	0.60	0.40	$\pm 20\%$	$\pm 20\%$
	ESVB30G107M	100	B3	4.0	0.20	0.38	0.22	$\pm 15\%$	$\pm 15\%$
	ESVB20G107M	100	B2	4.0	0.12	0.22	0.14	$\pm 12\%$	$\pm 12\%$
	ESVB20G157M	150	B2	6.0	0.18	0.34	0.20	$\pm 12\%$	$\pm 12\%$
	ESVB20G227M	220	B2	8.8	0.18	0.34	0.20	$\pm 12\%$	$\pm 12\%$
ESVC0G227M	220	C	8.8	0.12	0.22	0.14	$\pm 12\%$	$\pm 12\%$	
ESVC0G337M	330	C	13.2	0.14	0.26	0.16	$\pm 12\%$	$\pm 12\%$	
ESVVOG337M	330	V	13.2	0.12	0.18	0.14	$\pm 12\%$	$\pm 12\%$	
ESVD0G477M	470	D	18.8	0.16	0.30	0.18	$\pm 12\%$	$\pm 12\%$	
ESVD0G687M	680	D	27.2	0.24	0.46	0.26	$\pm 12\%$	$\pm 12\%$	
6.3	ESVPOJ155M	1.5	P	0.5	0.10	0.15	0.15	$\pm 20\%$	$\pm 20\%$
	ESVJ0J225M	2.2	J	0.5	0.20	0.30	0.30	$\pm 20\%$	$\pm 20\%$
	ESVJ0J335M	3.3	J	0.5	0.20	0.30	0.30	$\pm 20\%$	$\pm 20\%$
	ESVJ0J475M	4.7	J	0.5	0.20	0.30	0.30	$\pm 20\%$	$\pm 20\%$
	ESVPOJ475M	4.7	P	0.5	0.20	0.30	0.30	$\pm 20\%$	$\pm 20\%$
	ESVA0J475M	4.7	A	0.5	0.08	0.12	0.10	$\pm 5\%$	$\pm 10\%$
	ESVJ0J685M	6.8	J	0.5	0.20	0.30	0.30	$\pm 20\%$	$\pm 20\%$
	ESVPOJ685M	6.8	P	0.5	0.20	0.30	0.30	$\pm 20\%$	$\pm 20\%$
	ESVA20J685M	6.8	A2	0.5	0.08	0.12	0.10	$\pm 12\%$	$\pm 12\%$
	ESVJ0J106M	10	J	0.63	0.20	0.38	0.22	$\pm 20\%$	$\pm 20\%$
	ESVPOJ106M	10	P	0.6	0.20	0.30	0.30	$\pm 20\%$	$\pm 20\%$
	ESVA20J106M	10	A2	0.6	0.08	0.12	0.10	$\pm 12\%$	$\pm 12\%$
	ESVA0J106M	10	A	0.6	0.08	0.12	0.10	$\pm 12\%$	$\pm 12\%$
	ESVA20J156M	15	A2	0.9	0.12	0.22	0.14	$\pm 12\%$	$\pm 12\%$
	ESVA0J156M	15	A	0.9	0.08	0.12	0.10	$\pm 12\%$	$\pm 12\%$
	ESVA20J226M	22	A2	1.3	0.12	0.22	0.14	$\pm 12\%$	$\pm 12\%$
	ESVA0J226M	22	A	1.3	0.10	0.14	0.12	$\pm 12\%$	$\pm 12\%$
	ESVB30J226M	22	B3	1.3	0.08	0.12	0.10	$\pm 15\%$	$\pm 15\%$
ESVB20J226M	22	B2	1.3	0.08	0.12	0.10	$\pm 5\%$	$\pm 10\%$	
ESVA0J336M	33	A	2.0	0.12	0.22	0.14	$\pm 12\%$	$\pm 12\%$	
ESVB30J336M	33	B3	2.0	0.12	0.18	0.15	$\pm 15\%$	$\pm 15\%$	

Rating (V)	Part Number	Capacitance (μF)	Case Code	DC Leakage Current (μA)	Tangent of Loss Angle			Capacitance Change	
					+20°C +85°C	-55°C	+125°C	at Damp Heat at Resistance to Soldering Heat	at Endurance
6.3	ESVA0J476M	47	A	3.0	0.12	0.22	0.14	±12%	±12%
	ESVB30J476M	47	B3	2.9	0.12	0.18	0.15	±15%	±15%
	ESVB20J476M	47	B2	2.9	0.08	0.12	0.10	± 5%	±10%
	ESVC0J476M	47	C	2.9	0.08	0.12	0.10	± 5%	±10%
	ESVB20J686M	68	B2	4.2	0.10	0.18	0.12	±12%	±12%
	ESVB20J107M	100	B2	6.3	0.12	0.22	0.14	±12%	±12%
	ESVC20J107M	100	C2	6.3	0.10	0.18	0.12	±12%	±12%
	ESVC0J107M	100	C	6.3	0.10	0.14	0.12	±12%	±12%
	ESVC0J157M	150	C	9.4	0.10	0.18	0.12	±12%	±12%
	ESVC0J227M	220	C	13.8	0.14	0.26	0.16	±12%	±12%
	ESVV0J227M	220	V	13.8	0.12	0.18	0.14	±12%	±12%
	ESVD0J227M	220	D	13.8	0.12	0.18	0.14	±12%	±12%
	ESVD0J337M	330	D	20.7	0.14	0.26	0.16	±12%	±12%
ESVD0J477M	470	D	29.7	0.20	0.38	0.22	±20%	±20%	
10	ESVP1A105M	1.0	P	0.5	0.10	0.15	0.15	±20%	±20%
	ESVJ1A155M	1.5	J	0.5	0.20	0.30	0.30	±20%	±20%
	ESVP1A155M	1.5	P	0.5	0.20	0.30	0.30	±20%	±20%
	ESVJ1A225M	2.2	J	0.5	0.20	0.30	0.30	±20%	±20%
	ESVP1A225M	2.2	P	0.5	0.20	0.30	0.30	±20%	±20%
	ESVP1A335M	3.3	P	0.5	0.20	0.30	0.30	±20%	±20%
	ESVA21A335M	3.3	A2	0.5	0.08	0.12	0.10	±12%	±12%
	ESVP1A475M	4.7	P	0.5	0.20	0.30	0.30	±20%	±20%
	ESVA21A475M	4.7	A2	0.5	0.08	0.12	0.10	±12%	±12%
	ESVA1A475M	4.7	A	0.5	0.08	0.12	0.10	±12%	±12%
	ESVA1A685M	6.8	A	0.6	0.08	0.12	0.10	±12%	±12%
	ESVA21A106M	10	A2	1.0	0.08	0.12	0.10	±12%	±12%
	ESVA1A106M	10	A	1.0	0.08	0.12	0.10	±12%	±12%
	ESVB21A106M	10	B2	1.0	0.08	0.12	0.10	± 5%	±10%
	ESVB31A156M	15	B3	1.5	0.12	0.18	0.15	±15%	±15%
	ESVA1A226M	22	A	2.2	0.12	0.22	0.14	±12%	±12%
	ESVB31A226M	22	B3	2.2	0.08	0.12	0.10	±15%	±15%
	ESVB21A226M	22	B2	2.2	0.08	0.12	0.10	± 5%	±10%
	ESVB21A336M	33	B2	3.3	0.08	0.12	0.10	± 5%	±10%
	ESVB21A476M	47	B2	4.7	0.08	0.12	0.10	±12%	±12%
	ESVC21A476M	47	C2	4.7	0.08	0.12	0.10	±12%	±12%
ESVC1A476M	47	C	4.7	0.08	0.12	0.10	± 5%	±10%	
ESVC1A686M	68	C	6.8	0.08	0.12	0.10	±12%	±12%	
ESVC1A107M	100	C	10.0	0.10	0.18	0.12	±12%	±12%	
ESVD1A107M	100	D	10.0	0.08	0.18	0.10	± 5%	±10%	
ESVD1A157M	150	D	15.0	0.10	0.18	0.12	±12%	±12%	
ESVD1A227M	220	D	22.0	0.12	0.22	0.14	±12%	±12%	
16	ESVP1C474M	0.47	P	0.5	0.10	0.15	0.15	±20%	±20%
	ESVP1C684M	0.68	P	0.5	0.10	0.15	0.15	±20%	±20%
	ESVJ1C105M	1.0	J	0.5	0.10	0.30	0.15	±20%	±20%
	ESVP1C105M	1.0	P	0.5	0.10	0.15	0.15	±20%	±20%
	ESVA1C155M	1.5	A	0.5	0.04	0.08	0.06	± 5%	±10%
	ESVA21C225M	2.2	A2	0.5	0.06	0.10	0.08	±12%	±12%
	ESVA1C225M	2.2	A	0.5	0.06	0.10	0.08	± 5%	±10%
	ESVA21C335M	3.3	A2	0.5	0.08	0.14	0.10	±12%	±12%
	ESVA1C335M	3.3	A	0.5	0.06	0.10	0.08	±12%	±12%
	ESVA21C475M	4.7	A2	0.7	0.08	0.14	0.10	±12%	±12%
	ESVA1C475M	4.7	A	0.7	0.06	0.10	0.08	±12%	±12%
	ESVA1C685M	6.8	A	1.0	0.06	0.10	0.08	±12%	±12%
	ESVB31C685M	6.8	B3	1.0	0.06	0.10	0.08	±15%	±15%
	ESVA1C106M	10	A	1.6	0.08	0.12	0.10	±12%	±12%
	ESVB31C106M	10	B3	1.6	0.08	0.14	0.10	±15%	±15%
	ESVB21C106M	10	B2	1.6	0.06	0.10	0.08	± 5%	±10%
	ESVB21C156M	15	B2	2.4	0.06	0.10	0.08	± 5%	±10%
	ESVB21C226M	22	B2	3.5	0.06	0.10	0.08	± 5%	±10%
ESVC1C226M	22	C	3.5	0.06	0.10	0.08	± 5%	±10%	

Rating (V)	Part Number	Capacitance (μF)	Case Code	DC Leakage Current (μA)	Tangent of Loss Angle			Capacitance Change	
					+20°C +85°C	-55°C	+125°C	at Damp Heat at Resistance to Soldering Heat	at Endurance
16	ESVC21C336M	33	C2	5.2	0.06	0.10	0.08	$\pm 12\%$	$\pm 12\%$
	ESVC1C336M	33	C	5.2	0.06	0.10	0.08	$\pm 5\%$	$\pm 10\%$
	ESVC1C476M	47	C	7.5	0.06	0.10	0.08	$\pm 12\%$	$\pm 12\%$
	ESVD1C476M	47	D	7.5	0.06	0.10	0.08	$\pm 5\%$	$\pm 10\%$
	ESVD1C686M	68	D	10.8	0.06	0.10	0.08	$\pm 5\%$	$\pm 10\%$
	ESVD1C107M	100	D	16.0	0.10	0.18	0.10	$\pm 12\%$	$\pm 12\%$
20	ESVA21D474M	0.47	A2	0.5	0.06	0.10	0.08	$\pm 5\%$	$\pm 10\%$
	ESVA21D684M	0.68	A2	0.5	0.06	0.10	0.08	$\pm 5\%$	$\pm 10\%$
	ESVA21D105M	1.0	A2	0.5	0.06	0.10	0.08	$\pm 12\%$	$\pm 12\%$
	ESVA21D155M	1.5	A2	0.5	0.06	0.10	0.08	$\pm 12\%$	$\pm 12\%$
	ESVA21D225M	2.2	A2	0.5	0.06	0.10	0.08	$\pm 12\%$	$\pm 12\%$
	ESVA1D225M	2.2	A	0.5	0.06	0.10	0.08	$\pm 12\%$	$\pm 12\%$
	ESVA1D335M	3.3	A	0.6	0.06	0.10	0.08	$\pm 12\%$	$\pm 12\%$
	ESVB31D335M	3.3	B3	0.6	0.06	0.10	0.08	$\pm 15\%$	$\pm 15\%$
	ESVA1D475M	4.7	A	0.9	0.06	0.10	0.08	$\pm 12\%$	$\pm 12\%$
	ESVB31D475M	4.7	B3	0.9	0.06	0.10	0.08	$\pm 15\%$	$\pm 15\%$
	ESVB21D475M	4.7	B2	0.9	0.06	0.10	0.08	$\pm 5\%$	$\pm 10\%$
	ESVB21D685M	6.8	B2	1.3	0.06	0.10	0.08	$\pm 5\%$	$\pm 10\%$
	ESVB21D106M	10	B2	2.0	0.06	0.10	0.08	$\pm 5\%$	$\pm 10\%$
	ESVC1D156M	15	C	3.0	0.06	0.10	0.08	$\pm 5\%$	$\pm 10\%$
	ESVC21D226M	22	C2	4.4	0.06	0.10	0.08	$\pm 12\%$	$\pm 12\%$
	ESVC1D226M	22	C	4.4	0.06	0.10	0.08	$\pm 5\%$	$\pm 10\%$
ESVD1D226M	22	D	4.4	0.06	0.10	0.08	$\pm 5\%$	$\pm 10\%$	
ESVD1D336M	33	D	6.6	0.06	0.10	0.08	$\pm 5\%$	$\pm 10\%$	
ESVD1D476M	47	D	9.4	0.06	0.10	0.08	$\pm 5\%$	$\pm 10\%$	
25	ESVA1E474M	0.47	A	0.5	0.04	0.08	0.06	$\pm 5\%$	$\pm 10\%$
	ESVA1E684M	0.68	A	0.5	0.06	0.10	0.08	$\pm 5\%$	$\pm 10\%$
	ESVA21E105M	1.0	A2	0.5	0.06	0.10	0.08	$\pm 12\%$	$\pm 12\%$
	ESVA1E105M	1.0	A	0.5	0.06	0.10	0.08	$\pm 5\%$	$\pm 10\%$
	ESVA1E225M	2.2	A	0.5	0.06	0.10	0.08	$\pm 12\%$	$\pm 12\%$
	ESVA1E335M	3.3	A	0.8	0.06	0.10	0.08	$\pm 12\%$	$\pm 12\%$
	ESVB21E475M	4.7	B2	1.1	0.06	0.10	0.08	$\pm 5\%$	$\pm 10\%$
	ESVC1E106M	10	C	2.5	0.06	0.10	0.08	$\pm 5\%$	$\pm 10\%$
ESVD1E226M	22	D	5.5	0.06	0.10	0.08	$\pm 5\%$	$\pm 10\%$	
35	ESVA1V474M	0.47	A	0.5	0.06	0.10	0.08	$\pm 5\%$	$\pm 10\%$
	ESVA1V684M	0.68	A	0.5	0.06	0.10	0.08	$\pm 5\%$	$\pm 10\%$
	ESVA21V105M	1.0	A2	0.5	0.06	0.10	0.08	$\pm 12\%$	$\pm 12\%$
	ESVA1V105M	1.0	A	0.5	0.06	0.10	0.08	$\pm 12\%$	$\pm 12\%$
	ESVA1V155M	1.5	A	0.5	0.06	0.10	0.08	$\pm 12\%$	$\pm 12\%$
	ESVB21V225M	2.2	B2	0.7	0.06	0.10	0.08	$\pm 5\%$	$\pm 10\%$
	ESVB21V335M	3.3	B2	1.1	0.06	0.10	0.08	$\pm 5\%$	$\pm 10\%$
	ESVC1V475M	4.7	C	1.6	0.06	0.10	0.08	$\pm 5\%$	$\pm 10\%$
	ESVC1V685M	6.8	C	2.3	0.06	0.10	0.08	$\pm 5\%$	$\pm 10\%$
	ESVD1V106M	10	D	3.5	0.06	0.10	0.08	$\pm 5\%$	$\pm 10\%$
ESVD1V156M	15	D	5.2	0.06	0.10	0.08	$\pm 5\%$	$\pm 10\%$	

TAPE AND REEL SPECIFICATIONS

Plastic Tape Carrier

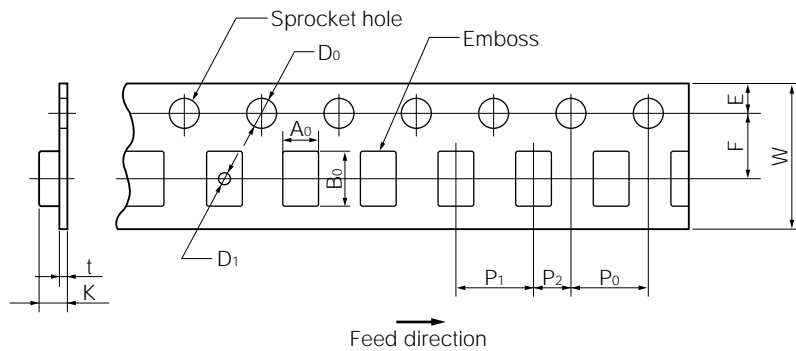

Unit: mm

Case Code	$A_0 \pm 0.2$	$B_0 \pm 0.2$	$K \pm 0.2$
J	1.0	1.8	1.1
P	1.4	2.2	1.4
A2 (U)	1.9	3.5	1.4
A	1.9	3.5	1.9
B3	3.2	3.8	1.4
B2 (S)	3.3	3.8	2.1
C2	3.7	6.4	1.7
C	3.7	6.4	3.0
V	4.6	7.7	2.4
D	4.8	7.7	3.3

Case Code	$W \pm 0.3$	$F \pm 0.05$	$E \pm 0.1$	$P_1 \pm 0.1$	$P_2 \pm 0.05$	$P_0 \pm 0.1$	$D_0^{+0.1}$	D_1 min.	t
J	8	3.5	1.75	4	2	4	$\phi 1.5$	-	0.2
P								-	
A2 (U)								$\phi 1.0$	
A									
B3 (W)									
B2 (S)	2.6	5.5	8	8	8	$\phi 1.5$	$\phi 1.5$	0.3	
C2									
C									
V									
D								0.3	

REEL

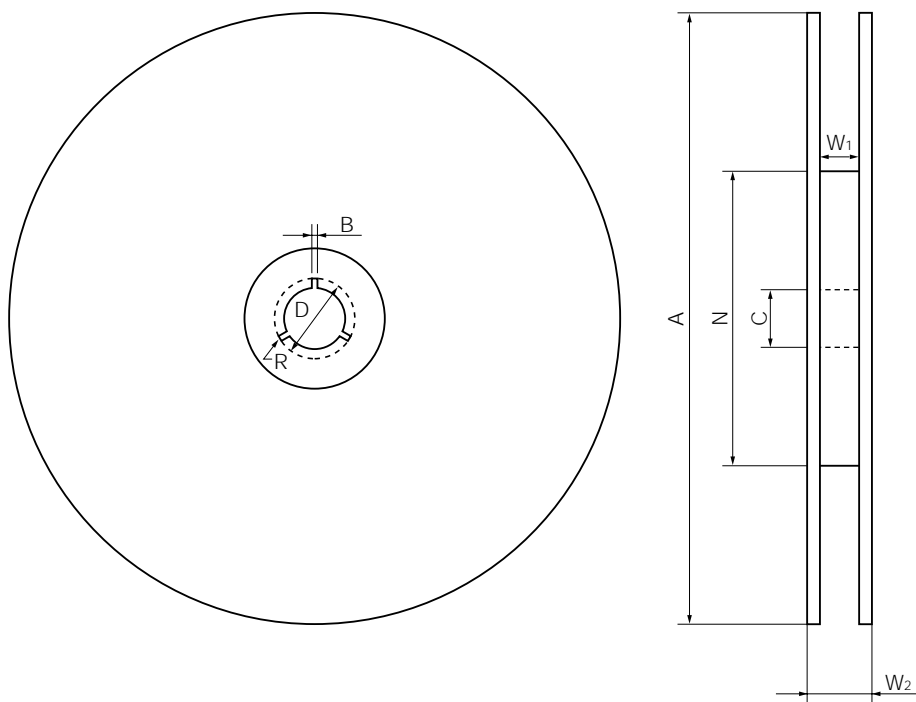

Unit: mm

Tape Width	A ± 2	N Min.	C ± 0.5	D ± 0.5	B ± 0.5	W ₁	W ₂ Max.	R
8 mm	φ180	φ50	φ13	φ21	2	9.0 ± 0.3	11.4 ± 1.0	1
12 mm						13.0 ± 0.3	15.4 ± 1.0	
8 mm	φ330	φ80	φ13	φ21	2	9.5 ± 0.5	14.5 Max.	1
12 mm						13.5 ± 0.5	18.5 Max.	

Case Code	φ180 Reel	φ330 Reel
J	4000	—
P	3000	—
A2 (U)	3000	10,000
A	2000	9000
B3 (W)	3000	—
B2 (S)	2000	5000
C2	1000	—
V	1000	3000
C, D	500	2500

[Quantity Per Reel]

NOTES ON USING THE SOLID TANTALUM CAPACITORS

About 90% of the failure mode of the solid tantalum capacitor is short-circuit. Please take surplus for the operating condition.

1. Circuit Design

(1) Reliability

The reliability of the solid tantalum capacitor is heavily influenced by environmental conditions such as temperature, humidity, shock, vibration, mechanical stresses, and electric stresses, including applied voltage, current, ripple current, transient current and voltage, and frequency. When using solid tantalum capacitors, therefore, provide enough margin so that the reliability of the capacitors is maintained.

Voltage and temperature are important parameters when estimating the reliability (field failure rate).

The field failure rate of a solid tantalum capacitor can be calculated by the following expression if emphasis is placed only on the voltage and temperature:

$$\lambda = \lambda_0(V/V_0)^3 \times 2^{(T-T_0)/10}$$

Where

- λ : estimated failure rate in actual working condition
temperature: T; voltage: V
- λ_0 : failure rate under rated load (See table below.)
temperature: T_0 ; voltage: V_0

Failure rate level λ_0 of each series

Series	Failure rate level
PS/L	1%/1000 h
E/SV	1%/1000 h
R (standard)	1%/1000 h
R (extended)	1%/1000 h
SV/S	1%/1000 h
SV/Z	1%/1000 h

<Test conditions>

Temperature: 85°C
Voltage: rated voltage
Rs: 3 Ω

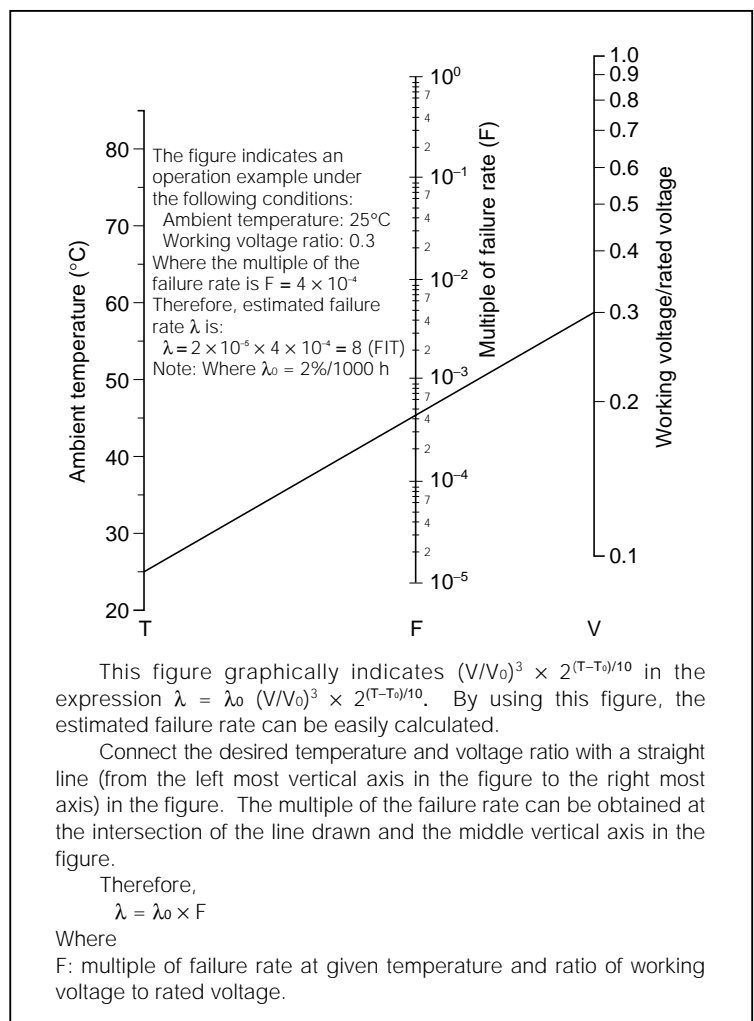

This figure graphically indicates $(V/V_0)^3 \times 2^{(T-T_0)/10}$ in the expression $\lambda = \lambda_0 (V/V_0)^3 \times 2^{(T-T_0)/10}$. By using this figure, the estimated failure rate can be easily calculated.

Connect the desired temperature and voltage ratio with a straight line (from the left most vertical axis in the figure to the right most axis) in the figure. The multiple of the failure rate can be obtained at the intersection of the line drawn and the middle vertical axis in the figure.

Therefore,

$$\lambda = \lambda_0 \times F$$

Where

F: multiple of failure rate at given temperature and ratio of working voltage to rated voltage.

2. Ripple Voltage

- (1) Keep the sum of the DC voltage and peak value of the ripple voltage within the rated voltage.
- (2) If a ripple voltage is applied to the capacitor, the peak value of the ripple voltage must be kept within the values shown in the following figures:

Chips

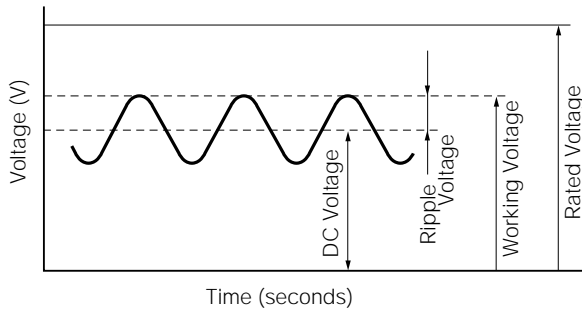
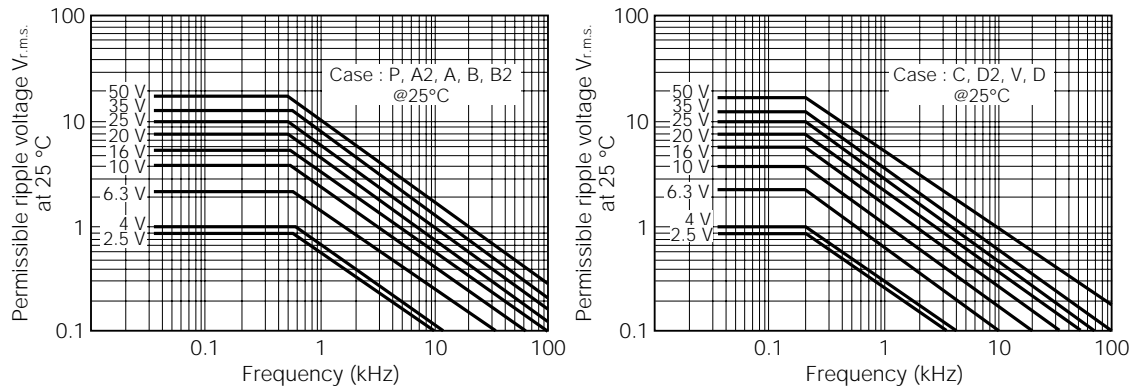

Calculate the permissible ripple voltage at a temperature higher than that specified in these figures by using the following expressions:

$$V_{r.m.s.} \text{ (at } 50^{\circ}\text{C)} = 0.7 \times V_{r.m.s.} \text{ (at } 25^{\circ}\text{C)}$$

$$V_{r.m.s.} \text{ (at } 85^{\circ}\text{C)} = 0.5 \times V_{r.m.s.} \text{ (at } 25^{\circ}\text{C)}$$

$$V_{r.m.s.} \text{ (at } 125^{\circ}\text{C)} = 0.3 \times V_{r.m.s.} \text{ (at } 25^{\circ}\text{C)}$$

- (3) Keep the negative peak value of the ripple voltage within the permissible reverse voltage value specified in the following section, Reverse Voltage.

3. Reverse Voltage

- (1) Because the solid tantalum capacitor is of polar type, do not apply a reverse voltage to it. If reverse voltage cannot be avoided, it must be applied for a short time and must not exceed the following values:
 25°C..... 10% max. of rated voltage or 3 Vdc, whichever is smaller
 85°C..... 5% max. of rated voltage
 125°C..... 1% max. of rated voltage

- (2) The figure on the right shows the relationship between current and reverse voltage.

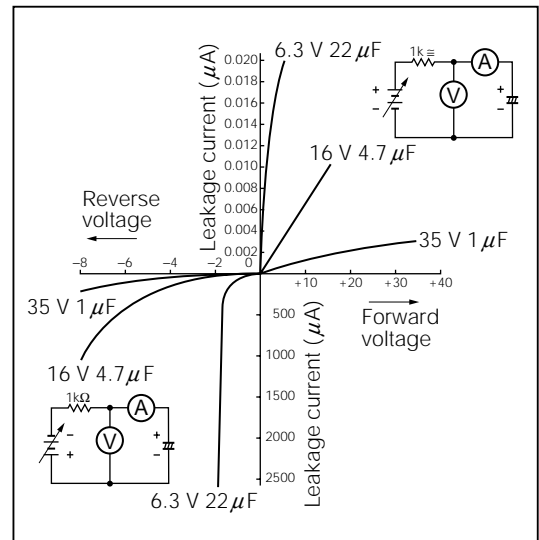

4. Applied Voltage

- (1) For general applications, apply 70% or less of the rated voltage to the capacitor.
- (2) When the capacitor is used in a power line or a low-impedance circuit, keep the applied voltage within 30% (50% max.) of the rated voltage to avoid the adverse influence of inrush current.
- (3) Derated voltage at 85°C or more.

When using a Chip-type capacitor at a temperature of 85°C or higher, calculate reduced voltage U_T from the following expression. Note, however, that the ambient temperature must not exceed 125°C.

The rated voltage ratio is as shown in the figure on the right.

$$U_T = V_0 \frac{U_R - U_C}{40} (T - 85)$$

Where

U_R : rated voltage (V)

U_C : derated voltage at 125°C

T : ambient temperature (°C)

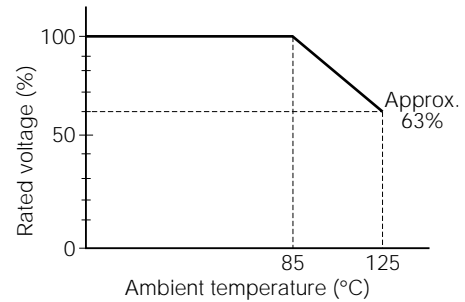

5. Current (Series Resistance)

As shown in the figure on the right, reliability is increased by inserting a series resistance of at least $3\Omega/V$ into circuits where current flow is momentary (switching circuits, charge/discharge circuits, etc). If the capacitor is in a low-impedance circuit, the voltage applied to the capacitor should be less than 1/2 to 1/3 of the DC rated voltage.

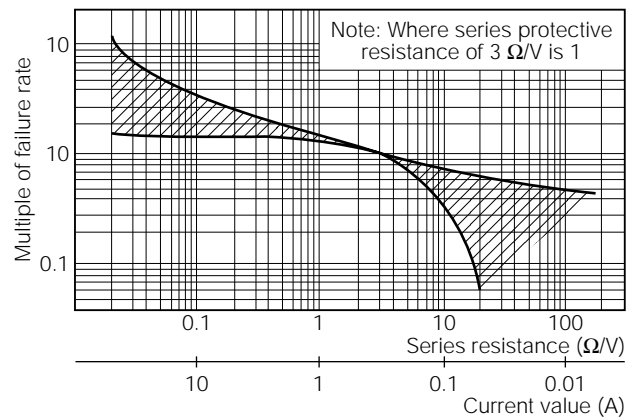

6. In the Case of Short-Circuit

- (1) Manganese oxide tantalum capacitor (conventional tantalum capacitor) is heated and may generate fire and be burned depending upon its excess current, time and other factors.
- (2) Conductive polymer tantalum capacitor (NeoCapacitor) is heated and may generate smoke emission depending upon its excess current, time and other factors.

(Conductive polymer used for electrolyte is superior in insulating the damaged portion to manganese oxide (used in conventional tantalum capacitor).)

When designing the circuit, provide as much margin as possible to maintain capacitor reliability.

NOTES ON USING THE CHIP TANTALUM CAPACITORS, EXCLUDING NeoCapacitors

1. Mounting

(1) Direct Soldering

Keep the following points in mind when soldering the capacitor by means of jet soldering or dip soldering:

(a) Temporarily fixing resin

Because chip tantalum capacitors are larger and subject to more force than chip multilayer ceramic capacitors or chip resistors, more resin is required to temporarily secure the solid tantalum capacitors. However, if too much resin is used, the resin adhering to the patterns on a printed circuit board may adversely affect the solderability.

(b) Pattern design

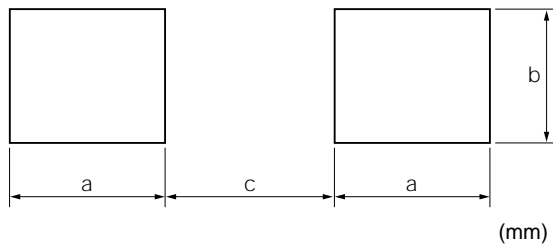

Case	a	b	c
P	2.2	1.4	0.7
A2 (U), A	2.9	1.7	1.2
B3 (W), B2 (S)	3.0	2.8	1.6
B	3.3	1.9	2.4
C	4.1	2.3	2.4
D2	5.4	2.9	2.4
D	5.2	2.9	3.7

The above dimensions are for reference only. If the capacitor is to be mounted by this method, and if the pattern is too small, the solderability may be degraded.

(c) Temperature and time

Keep the peak temperature and time within the following values:

Solder temperature 260°C max.

Time 5 seconds max. (10 seconds max. for SVH)

Whenever possible, perform preheating (at 150°C max.) for a smooth temperature profile. To maintain reliability, mount the capacitor at low temperature and in a short time.

(d) Component layout

If many types of chip components are mounted on a printed circuit board that is to be soldered by means of jet soldering, solderability may not be uniform over the entire board, depending on the layout and density of the components on the board (also take into consideration generation of flux gas).

(e) Flux

Use resin-based flux. Do not use flux with strong acidity.

(2) Reflow Soldering

Keep the following points in mind when soldering the capacitor in a soldering oven or with a hot plate:

(a) Pattern design (in accordance with IEC1188)

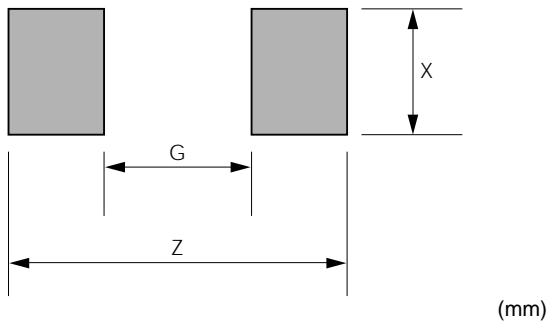

Case	G Max.	Z Min.	X Min.
J	0.7	2.5	1.0
P	0.5	2.6	1.2
A2 (U), A	1.1	3.8	1.5
B3 (W), B2 (S)	1.4	4.1	2.7
B	2.6	5.6	2.9
C	2.9	6.9	2.7
D2 (T)	2.7	6.7	2.9
D	4.1	8.2	2.9

The above dimensions are recommended. Note that if the pattern is too big, the component may not be mounted in place.

(b) Temperature and time

Keep the peak temperature and time within the following values:

- Solder temperature 260°C max.
- Time 10 seconds max.

Whenever possible, perform preheating (at 150°C max.) for a smooth temperature profile. To maintain reliability, mount the capacitor at low temperature and in a short time. The peak temperature and time shown above are applicable when the capacitor is to be soldered in a soldering oven or with a hot plate. When the capacitor is soldered by means of infrared reflow soldering, the internal temperature of the capacitor may rise beyond the surface temperature.

(3) Using a Soldering Iron

When soldering the capacitor with a soldering iron, controlling the temperature at the tip of the soldering iron is very difficult. However, it is recommended that the following temperature and time be observed to maintain the reliability of the capacitor:

- Iron temperature 300°C max.
- Time 3 seconds max.
- Iron power 30 W max.

2. Cleaning

Generally, several organic solvents are used for flux cleaning of an electronic component after soldering. Many cleaning methods, such as immersion cleaning, rinse cleaning, brush cleaning, shower cleaning, vapor cleaning, and ultrasonic cleaning, are available; cleaning methods may be used alone or two or more may be used in combination. The temperature of the organic solvent may vary from room temperature to several 10°C, depending on the desired effect. If cleaning is carried out with emphasis placed only on the cleaning effect, however, the marking on the electronic component cleaned may be erased, the appearance of the component may be damaged, and, in the worst case, the component may be functionally damaged. It is therefore recommended that the R series solid tantalum capacitor be cleaned under the following conditions:

Recommended conditions of flux cleaning

- (1) Cleaning solvent Chlorosen, isopropyl alcohol
- (2) Cleaning method Shower cleaning, rinse cleaning, vapor cleaning
- (3) Cleaning time 5 minutes max.

Note. Ultrasonic cleaning

This cleaning method is extremely effective for eliminating dust generated by mechanical processes, but may pose problems depending on the condition. An experiment conducted by NEC TOKIN confirmed that the external terminals of the capacitor were cut when it was cleaned with some ultrasonic cleaning machines. The cause of this phenomenon is metal fatigue of the capacitor terminals due to ultrasonic cleaning. To prevent the terminal from being cut, decreasing the output power of the ultrasonic cleaning machine or shortening the cleaning time may be effective. However, it is difficult to specify the cleaning conditions because there are many factors involved, such as the conversion efficiency of the ultrasonic oscillator, transfer efficiency of the cleaning bath, difference in cleaning effect depending on the location in the cleaning bath, the size and quantity of the printed circuit boards to be cleaned, and the securing states of the components on the boards. It is therefore recommended that ultrasonic cleaning be avoided as much as possible.

If ultrasonic cleaning is essential, make sure through experiments that no abnormalities occur as a result of the cleaning. For further information, consult NEC TOKIN.

3. Other

- (1) Do not subject the capacitor to excessive vibration and shock.
- (2) The solderability of the capacitor may be degraded by humidity. Store the capacitor at room temperature (–5 to +40°C) and humidity (40 to 60% RH).
- (3) Take care that no external force is applied to tape-packaged products (if the packaging material is deformed, the capacitor may not be automatically mounted by a chip mounter).

NOTES ON USING NeoCapacitors

1. Permissible Ripple Current

Permissible ripple current shall be derated as follows:

(1) Temperature Change

25°C: Rating value

85°C: 0.9 times rating value

105°C: 0.4 times rating value

(2) Switching Frequency

100 kHz: rating value

500 kHz: 1.1 times rating value

1 MHz: 1.3 times rating value

2. Mounting

This capacitor is designed to be surface mounted by means of reflow soldering.

(The conditions under which the capacitor should be soldered with a soldering iron are explained in (2) Using a Soldering Iron. Because the capacitor is not designed to be soldered by means of laser beam soldering, VPS, or flow soldering, the conditions for these soldering methods are not explained in this document.)

(1) Reflow Soldering

Keep the following points in mind when soldering the capacitor in a soldering oven with a hot plate:

(a) Pattern design (in accordance with IEC1188)

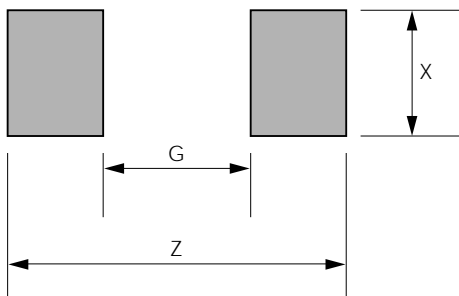

(mm)

Case	G Max.	Z Min.	X Min.
J	0.7	2.5	1.0
P	0.5	2.6	1.2
A2 (U), A	1.1	3.8	1.5
B3 (W), B2 (S)	1.4	4.1	2.7
C	2.9	6.9	2.7
V, D	4.1	8.2	2.9

The above dimensions are recommended. Note that if the pattern is too big, the component may not be mounted in place.

(b) Temperature and time

Keep the peak temperature and time within the following recommended conditions.

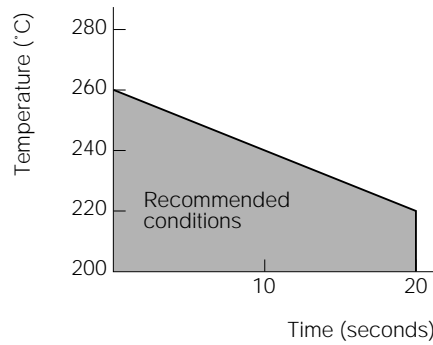

Whenever possible, perform preheating (at 150°C max.) for a smooth temperature profile. To maintain reliability, mount the capacitor at low temperature and in a short time. The peak temperature and time shown above are applicable when the capacitor is to be soldered in a soldering oven or with a hot plate. When the capacitor is soldered by means of infrared reflow soldering, the internal temperature of the capacitor may rise beyond the surface temperature.

(2) Using a Soldering Iron

When soldering the capacitor with a soldering iron, controlling the temperature at the tip of the soldering iron is very difficult. However, it is recommended that the following temperature and time be observed to maintain the reliability of the capacitor:

- Iron temperature ... 300°C max.
- Time 3 seconds max.
- Iron power 30 W max.

3. Cleaning

Generally, several organic solvents are used for flux cleaning of an electronic component after soldering. Many cleaning methods, such as immersion cleaning, rinse cleaning, brush cleaning, shower cleaning, vapor cleaning, and ultrasonic cleaning, are available, which may be used alone or in combination. The temperature of the organic solvent may vary from room temperature to several 10°C, depending on the desired effect. If cleaning is carried out with emphasis placed only on the cleaning effect, however, the marking on the electronic component cleaned may be erased, the appearance of the component may be damaged, and, in the worst case, the component may be functionally damaged. It is therefore recommended that the NeoCapacitor be cleaned under the following conditions:

[Recommended conditions of flux cleaning]

- (1) Cleaning solvent Isopropyl alcohol
- (2) Cleaning method Shower cleaning, rinse cleaning, vapor cleaning
- (3) Cleaning time 5 minutes max.

Note: Ultrasonic cleaning

This cleaning method is extremely effective for eliminating dust generated by mechanical processes, but may pose problems, depending on the condition. An experiment conducted by NEC TOKIN confirmed that the external terminals of the capacitor were cut when it was cleaned with some ultrasonic cleaning machines. The cause of this phenomenon is metal fatigue of the capacitor terminals due to ultrasonic cleaning. To prevent the terminal from being cut, decreasing the output power of the ultrasonic cleaning machine or decreasing the cleaning time may be effective. However, it is difficult to specify safe cleaning conditions because there are many factors involved, such as the conversion efficiency of the ultrasonic oscillator, transfer efficiency of the cleaning bath, difference in cleaning effect depending on the location in the cleaning bath, the size and quantity of the printed circuit boards to be cleaned, and the securing states of the components on the boards. It is therefore recommended that ultrasonic cleaning be avoided as much as possible.

If ultrasonic cleaning is essential, make sure through experiments that no abnormalities occur as a result of the cleaning. For further information, contact NEC TOKIN.

4. Derating

Apply appropriate voltage to the capacitors according to the failure rate estimation. It is recommended that the applied voltage be less than 80 % of the rated voltage.

5. Other

- (1) Do not subject the capacitor to excessive vibration and shock.
- (2) The solderability of the capacitor may be degraded by humidity. Store the capacitor at room temperature (–5 to +40°C) and humidity (40 to 60% RH).
- (3) Take care that no external force is applied to tape-packaged products (if the packaging material is deformed, the capacitor may not be automatically mounted by automatic insertion equipment).